



**M/ADÉ**  
By Petrič



**construction**

for  
construction  
machines

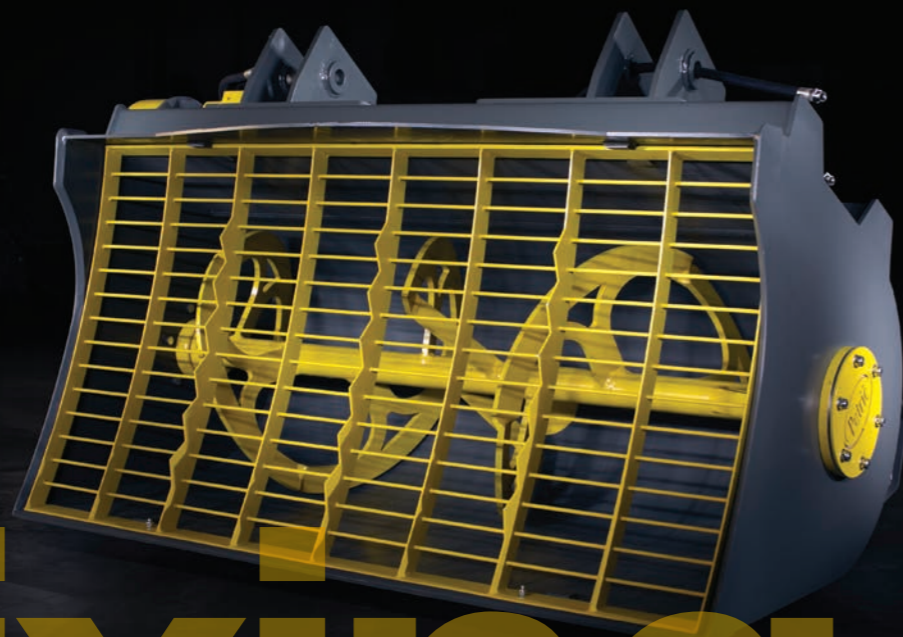

# Mixing BC

Mixing bucket can be used on any kind of construction machine; skid steer loaders, loaders, backhoe loaders, telehandlers, excavators, tractors...

#### MIXING BUCKET BC standard equipment:

- Safety grill with cement bag breaker
- Bottom, front side and mixer from abrasion resistant steel – HARDOX 450
- Hydraulic motor
- Chain tensioner
- Electromagnetic valve enables opening of discharge hatch
- Special design of hydraulically opened discharge hatch prevents any leakage of concrete milk
- Bucket is prepared for bolted attachment coupling to the machine
- 2 reinforcement bars on the back side
- Specially designed construction of bearing protection - minimal maintenance is required

#### MIXING BUCKET BC optional equipment:

- Bolted attachment connection for exact type of machine
- Discharge hose with coupling
- Safety valve for hydraulic motor

Note: Hydraulic hoses and el. cable from the bucket to the machine are not provided!

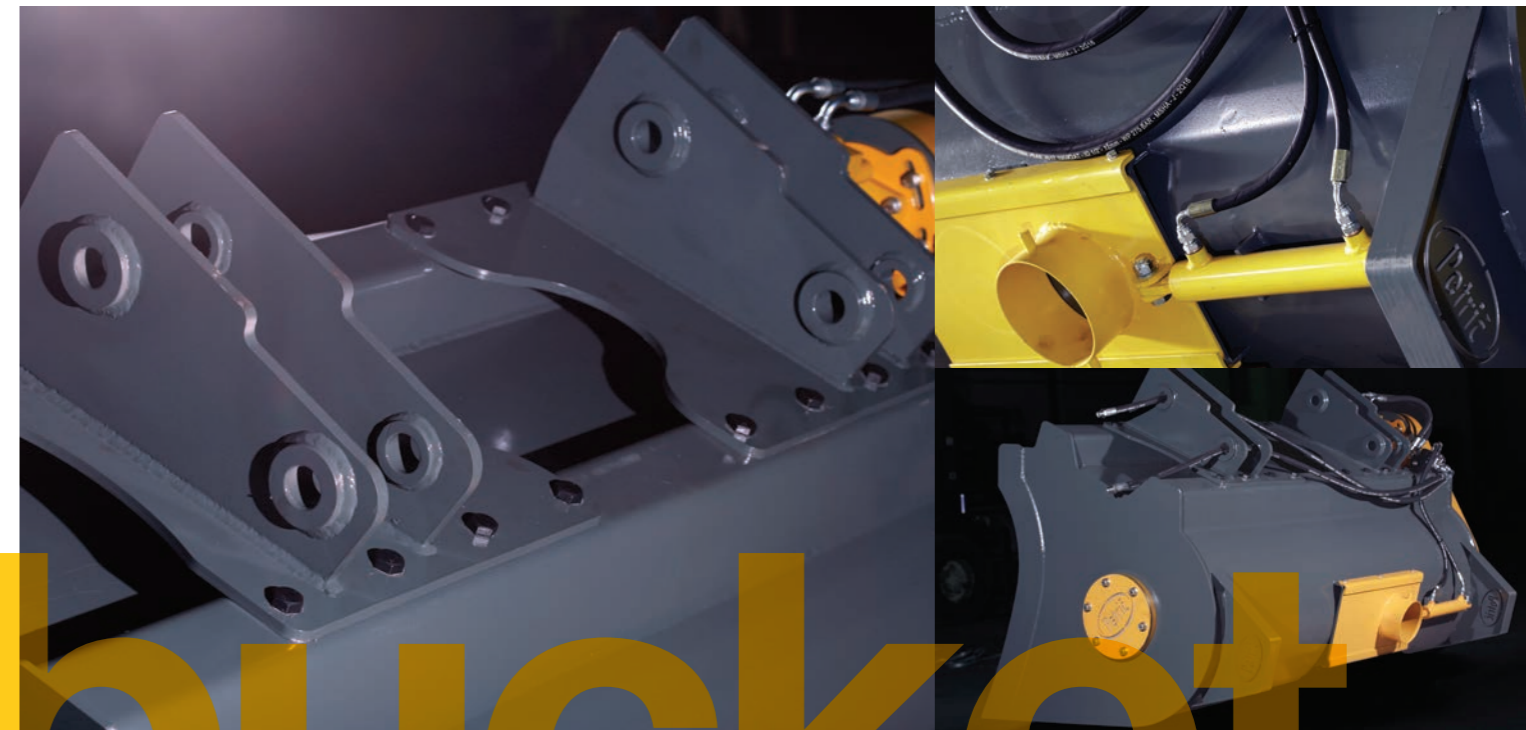

# bucket

TECHNICAL CHARACTERISTICS	Meas. unit	BC-25	BC-35	BC-50	BC-75
Load capacity	m <sup>3</sup>	0.25	0.35	0.50	0.75
Volume	l	300	430	650	900
Empty weight	kg	270	480	720	860
Total weight (with concrete)*	kg	870	1320	1920	2660
Attachment		on request	on request	on request	on request
Transmission		chain	chain	chain	chain
Working pressure	bar	200	200	160	140
Max. oil flow	l/min	75	75	125	125
Control voltage (Electromagnetic valve)	V	12 / 24	12 / 24	12 / 24	12 / 24
Dimension A	mm	702	881	948	1043
Dimension B	mm	763	827	1029	1139
Dimension C	mm	1224	1428	1836	1832
Angle	°	77	78	77	75
Overall dimensions	mm	1339x770x763	1558x971x827	2001x1143x1029	2004x1216x1139

\*at concrete specific weight 2400kg/m<sup>3</sup>

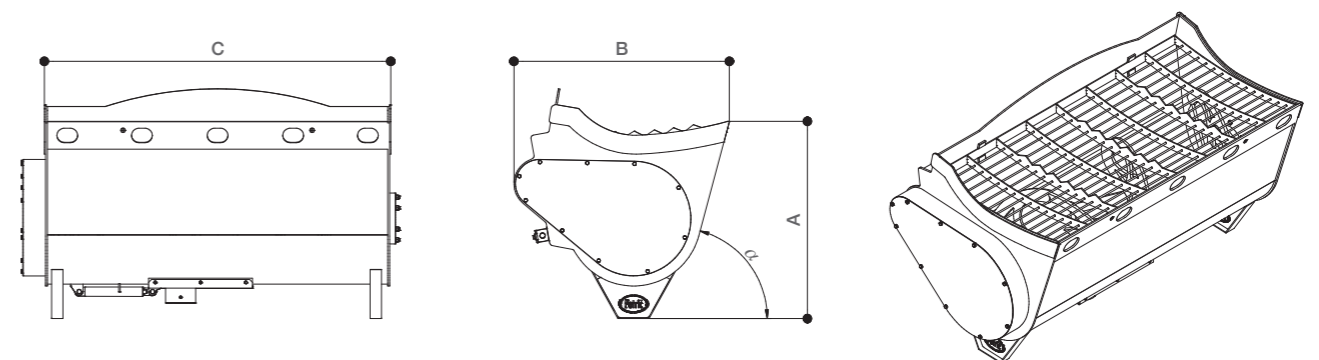

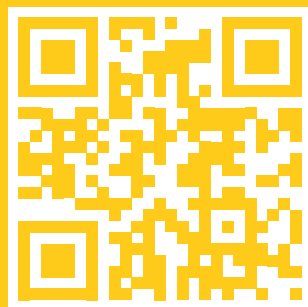

[madebypetric.si](http://madebypetric.si)



PETRIČ d.o.o., Goriška cesta 57, 5270 Ajdovščina, Slovenija  
[www.petric.si](http://www.petric.si), [petric@petric.si](mailto:petric@petric.si), tel. +386 5 365 90 00, fax. +386 5 365 90 22